



Residential Decks

City of Prior Lake Requirements

This handout is intended to be a guide only.

Specific code language can be found in the City Codes at: PriorLakeMN.gov

Planning and Zoning - Chapter 10 & MN Dept Labor & Industry: 2020 Minnesota Residential Code

SUBMITTALS FOR PERMIT:

May be submitted online at [Building Inspections/Permits | City of Prior Lake, MN](#)

PERMIT SUBMITTAL CHECKLIST:

- Building Permit application form.
- Certificate of Survey accurately indicating size and location of proposed deck. Property Surveys prior 2018 can be found at [Property Records](#) post 2018 [BS&A](#). If a survey is not in city records a current aerial photo may be utilized and obtained via [Scott County GIS](#).
- Deck Plans showing proposed designs and materials. Plans and Surveys shall be scanned to a pdf format, shall be drawn to scale with dimensions and shall include the following information:
 1. A floor plan indicating the following:
 - Size and spacing of floor joists and beams.
 - Size, location and spacing of posts/footings.
 - Size of decking and type of material.
 - Species and grade of lumber to be used.
 - Existing house rim-board and attachment method to existing house
 2. Elevations indicating the following:
 - Height of structure from established grade.
 - Spacing of intermediate rails (if any.)
 - Diameter and depth of footings.
 - Stairs (location and size)
 - Guardrail height (if any.)

REQUIRED INSPECTIONS: Call 952-952-447-9850 between 8:00 A.M. and 4:30 P.M. to schedule an inspection or email permits@priorlakemn.gov. Provide at least 24-hour advance notice and provide address and permit number.

- Footings:** After the holes are dug, **PRIOR TO POURING CONCRETE!** (Helical or Diamond Pier locations will be verified before framing starts)
- Framing:** Required before decking board placement for decks lower than 3 feet off the ground.
- Final:** When the structure has been completed.

GENERAL NOTES:

- The stamped, City approved Plan and Survey shall be kept on the job site and accessible to the building inspector until the final inspection has been conducted and approved.
- The Inspection Record Card shall be placed on an exterior wall of the home near the deck location and shall remain posted until the final inspection has been conducted and approved. Cards should be protected from the weather.
- Prior to digging, call Gopher State One Call at 811 to verify utility locations. Forty-eight-hour notice is required, excluding weekends and holidays. www.gopherstateonecall.org/homeowners

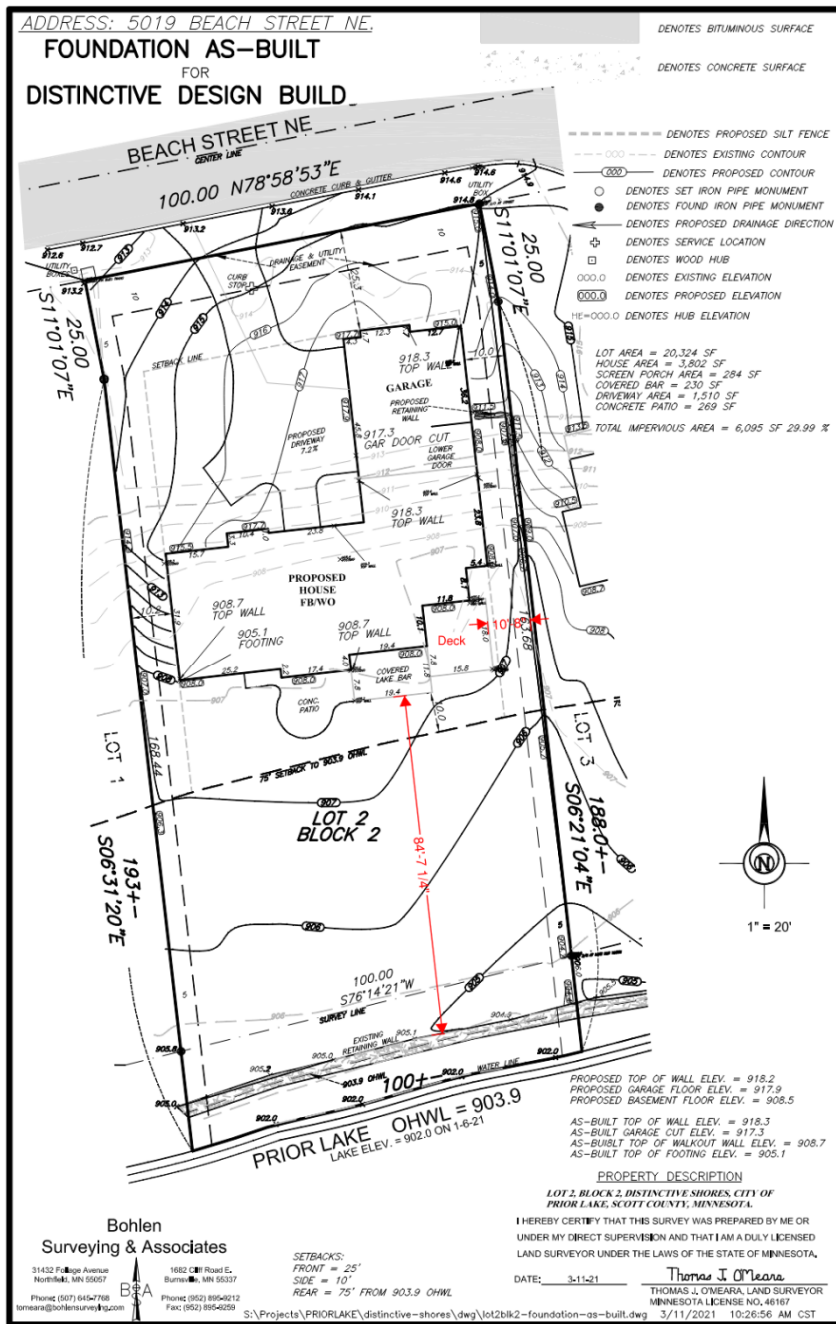

Examples shown are meant as a **GUIDE ONLY!!**

SAMPLE SURVEY

- Draw deck on survey to scale with dimensions showing proposed size.
- Property pins to be located by owner if required to verify setbacks.
- Show all existing structures, including pools and sheds.
- The Zoning Ordinance requires that decks maintain the following minimum setbacks in the R-1, R-2, and R-3 use districts:
 - Front: 25 feet
 - Side: 10' feet¹
 - Rear: 25 feet
 - Shoreland: 75 feet²
 - Wetland: 30 feet
 - Bluff: Minimum 25 feet³

¹Non-conforming lots of record in the R-1 and R-2 use districts may have a reduced setback, but no less than 5 feet. See City Code Chapter 10 article 3 section 10-345.

– Nonconformities.

²Shoreland ordinance permits the use of the average setback of those properties within 150 feet, but setback can be no less than 50 feet. See City Code Chapter 10 Article 4 Section 10-435(7).

- Shoreland

³Bluff setback is the upper end of a segment at least 25 feet in length having an average slope less than 18 percent.

- Replacement decks that do not meet the minimum required setbacks may be replaced provided the deck: (1) existed on May 1, 1999, (2) is (a) the same size and (b) location, (c) constructed of wood, and (d) not covered, and (3) not located within an easement, the public right-of-way or over a property line. In lieu of a survey a site plan may be accepted. A Site Plan is a to-scale plan showing setbacks, existing structures, dimensions, distance from lot lines and the proposed replacement deck.
- Decks with ¼ inch floorboard spacing are not considered impervious surface under the shoreland ordinance.

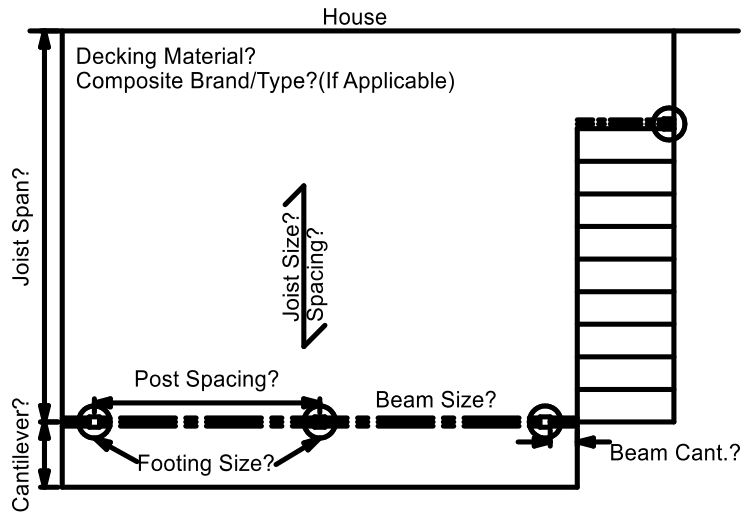

In your floor plan please including the following:

- Decking Material
- Composite brand/type if applicable
- Spacing in between posts
- Beam Size
- Post Size
- Joist Length, Size, and Spacing
- Joist Overhang (2' Max)
- Corner Footing Size
- Intermediate Footing Size
- Overall Deck Size
- Beam Overhang
- Type of Railing or Guard
- Height Above Ground
- If Cantilever: length and beams

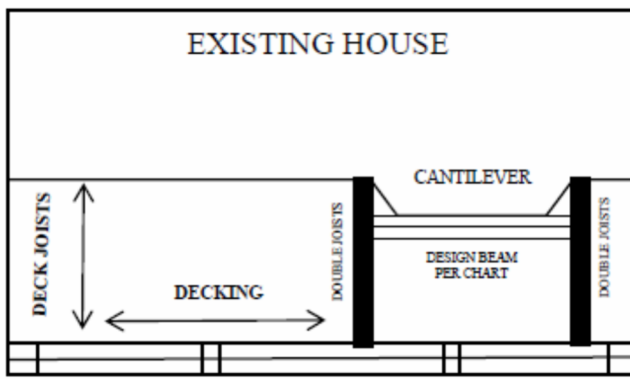

Many house designs have cantilevered (extensions) from the main structure, which typically contain patio doors, for future deck additions. The reinforcement selected will be based on the type of floor framing member presently in the house. Requirements: Add double joist outside of cantilever. Provide adequate hangers for all connections. Design center beam per chart. Lag bolt beam to cantilever ledger board.

(Provide all lumber sizes and dimensions shown above)

Sample Floor Plan

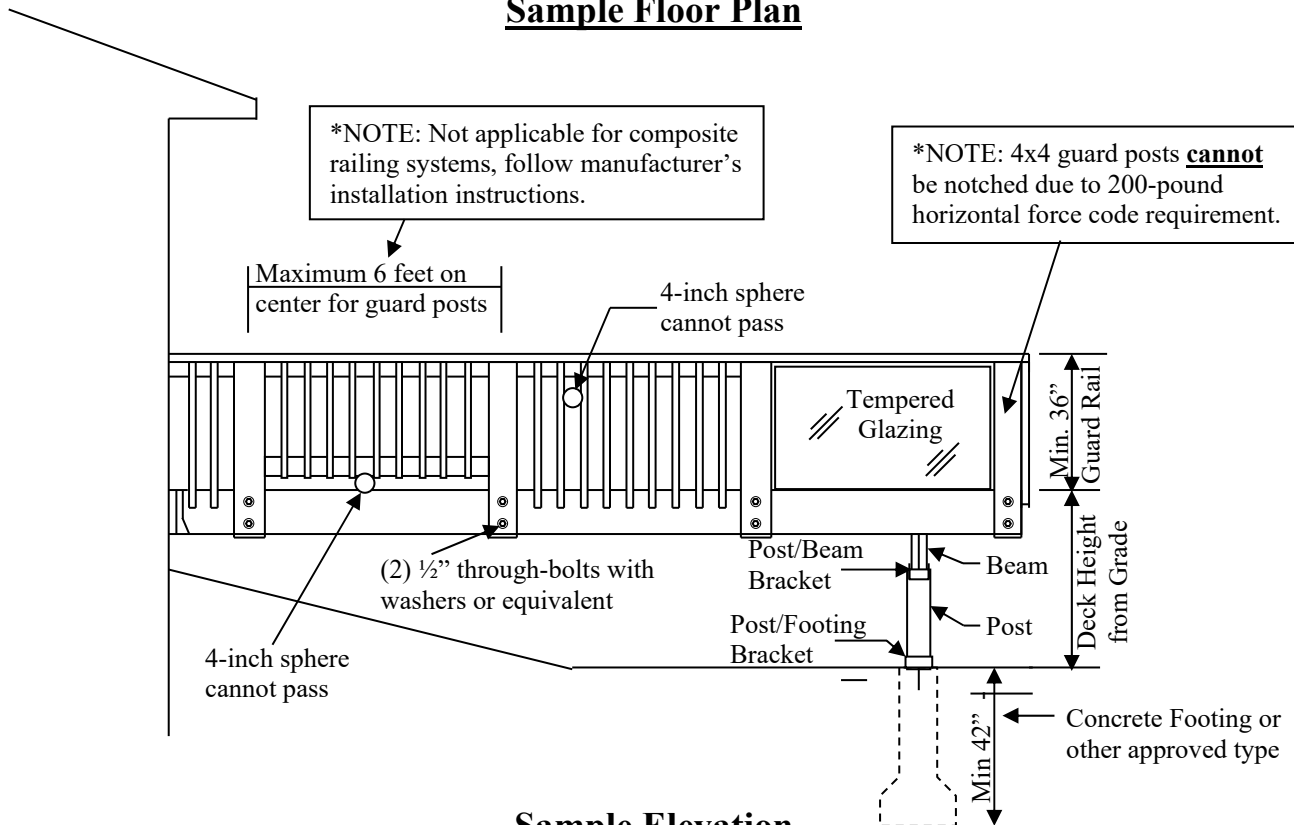

Sample Elevation

(Various guard systems shown, other systems can be used that meet code)

GENERAL BUILDING AND ZONING CODE REQUIREMENTS:

- Footings shall be designed and constructed below frost depth (42” minimum ground cover required from bottom of footing to grade or side slope.)
- Approved wood of natural resistance to decay or treated wood shall be used. Plastic composite decking and guardrails shall comply with ASTM D7032 and be installed per manufacturer’s instructions.
- Fasteners for pressure-preservative treated wood shall be of hot-dip zinc-coated galvanized per ASTM A153, stainless steel, silicon bronze or copper.

Exceptions: One-half inch (12.7mm) diameter or larger steel bolts. Fasteners other than nails and timber rivets shall be permitted to be of mechanically deposited zinc-coated in accordance with ASTM B695, Class 55 minimum.

- Only joist hanger nails (16d or 10d nails, 2-1/2” minimum length, in double shear nail holes) may be used in joist hangers with all holes filled. (Roofing nails and screws are prohibited.)
- Floor joists or stair stringers spaced at 16 inches OC. may use 5/4-inch minimum decking. (5/4-inch decking may be installed diagonally across 12” OC. joists, 2” decking diagonally across 16” OC (joists). **Refer to manufacturer’s install specifications for composite decking.**
- Decks shall be capable of supporting 40# per square foot live load and 10# per square foot dead load for a total load of 50# per square foot.
- **A special design is required for decks attached to house cantilevers.** Any beams used for framing around cantilevers must be let into the house wall and bear on the wall framing. Beams cannot be hung off ledger boards unless it is determined to be a marginal load such as a small stair landing.
- Posts for a deck shall be sized per this table.



Deck Post Size	Max Height
4 x 4	8’(supporting 1&2 ply beams), 6’-9”(3 ply beam)
4 x 6	8’
6 x 6	14’
8 x 8	14’

- **Decks built to support a future porch:** Posts must be at outer portion of deck rims; beam cantilevers are not permitted, and larger diameter footings may be required. Posts size may need to increase from the post size table for the additional load.
- **Lateral Load Connection now required by code:** Decks shall be attached to address lateral loads. Two examples are shown below:

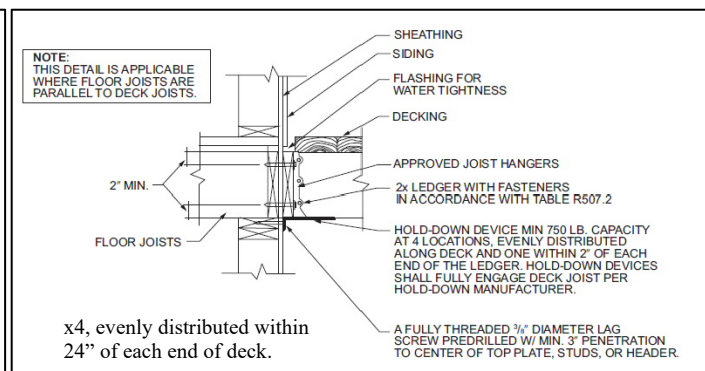
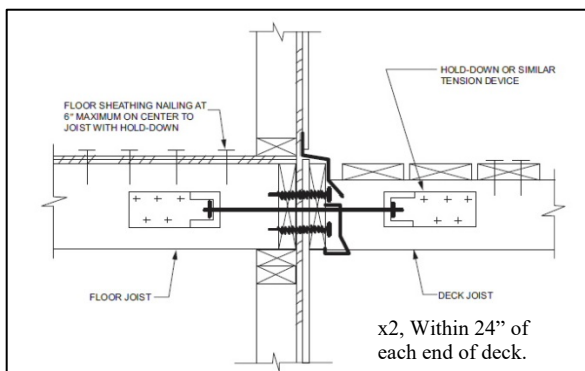

- Care should be given to properly flash the ledger board using a z-flashing installed over the top of the deck ledger with the house wrap weather barrier extending over the top of the z-flashing. Take care to **not** fasten the first deck board through the ledger flashing.

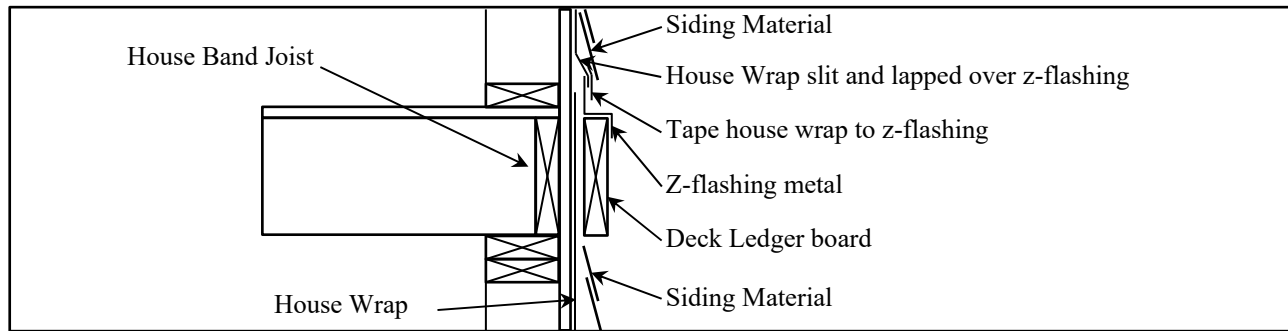

- Standard connection of a 2x ledger to a 2x Band Joist or 1" x 9-1/2" LVL is to be with 1/2" lag screws or bolts with washers in accordance with the tables below. Band Joist shall bear fully on the primary structure. (Other fasteners shall be pre-approved and installed per manufacturer.)

Fastener Spacing with a solid-sawn 2x or 1"x9-1/2" LVL Band Joist¹

JOIST SPAN	6' and less	6'-1" to 8'	8'-1" to 10'	10'-1" to 12'	12'-1" to 14'	14'-1" to 16'	16'-1" to 18'
Connection Details	On-center spacing of fasteners						
1/2" diameter lag screw with 1/2" maximum sheathing ^{2,3}	30	23	18	15	13	11	10
1/2" diameter bolt with 1/2" maximum sheathing ³	36	36	34	29	24	21	19
1/2" diameter bolt with 1" max. sheathing ⁴	36	36	29	24	21	18	16

¹ Ledgers shall be flashed to prevent water from contacting the house band joist.

² The tip of the lag screw shall fully extend beyond inside face of the band joist.

³ Sheathing shall be wood structural panel or solid sawn lumber.

⁴ Sheathing shall be permitted to be wood structural panel, gypsum board, fiberboard, lumber, or foam sheathing. Up to 1/2" thickness of stacked washers shall be permitted to substitute for up to 1/2" of allowable sheathing thickness where combined with wood structural panel or lumber sheathing.

Placement of lag screws and bolts in deck ledgers and band joists.

MINIMUM END AND EDGE DISTANCES AND SPACING BETWEEN ROWS				
	TOP EDGE	BOTTOM EDGE	ENDS	ROW SPACING
Ledger	2 inches	3/4 inch	2 inches	1-5/8 inches
Band Joist	3/4 inches	2 inches	2 inches	1-5/8 inches

^a Lag screws or bolts shall be staggered from the top to the bottom along the horizontal run of the deck ledger in accordance with Figure R507.9.1.3(1).

^b Maximum 5 inches.

^c For engineered rim board, the manufacturer's recommendations shall govern.

^d The minimum distance from bottom row of lag screws or bolts to the top edge of the ledger shall be in accordance with Figure R507.9.1.3(1).

Figure R507.9.1.3(1) – Placement of Lag Screws and Bolts in Ledgers

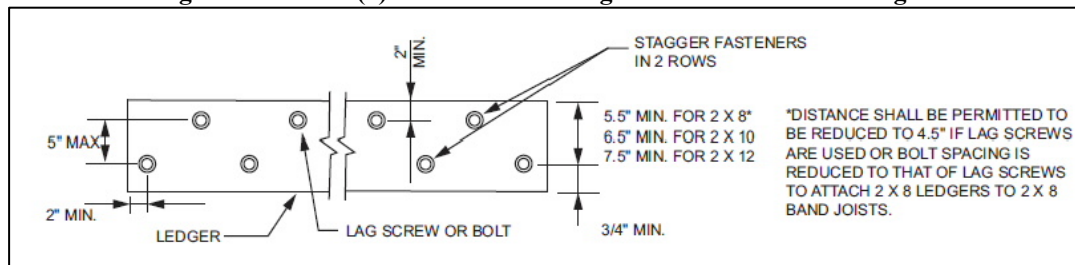

- Joists bearing on top of a multi-ply beam shall be fastened by mechanical fastener bracket or by toenails: 4-8d box (2.5"x0.113"); or 3-8d common (2.5"x0.131"); or 3-10d box (3"x0.128"); or 3-3"x 0.131" nails.
- Joist ends and bearing locations shall be provided with lateral resistance to prevent rotation. Blocking depth shall be at least 60% depth of joists. Rim joist to be attached with at least 3-No.10 x 3" screws.

- Ends of beams shall have minimum 1.5” bearing on wood or metal, and not less than 3” on concrete. For intermediate posts, each ply of the beam shall have full bearing on the post.

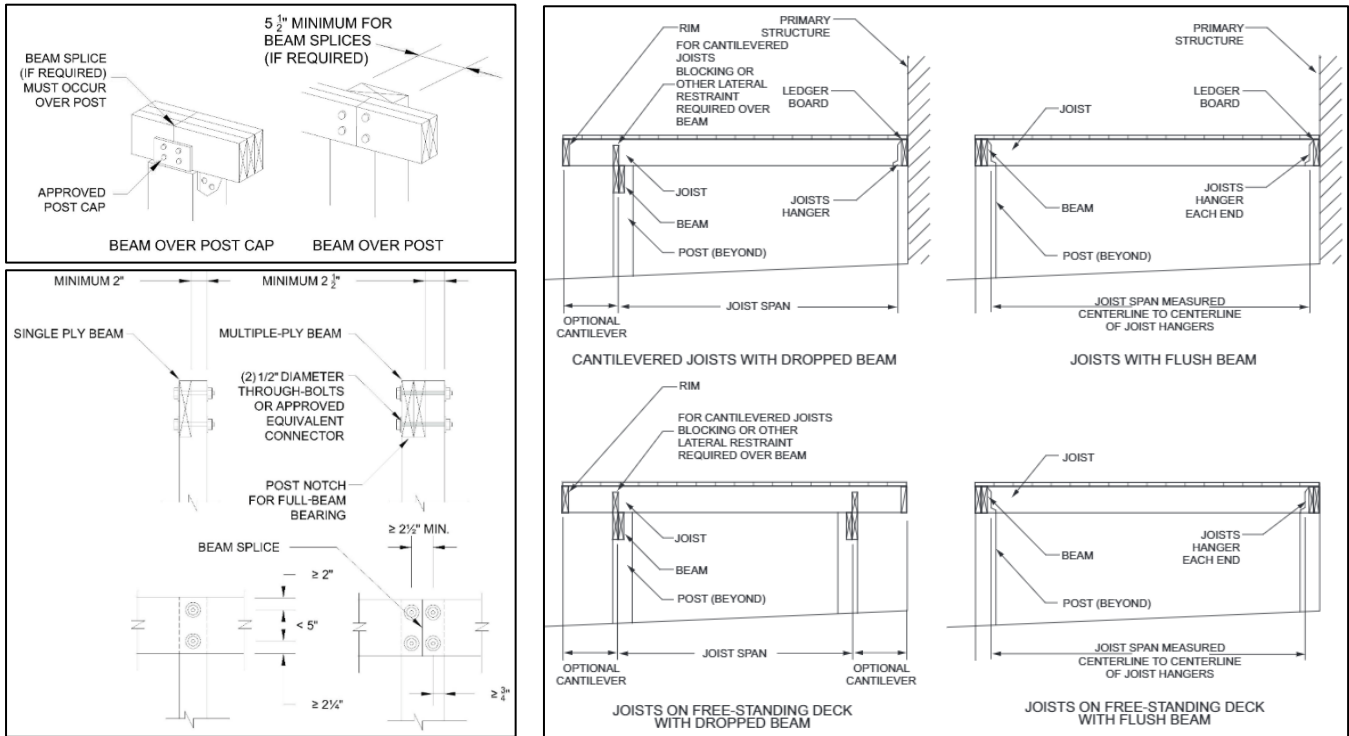

- Wood deck beams shall be permitted to cantilever at each end up to 1/4 of the allowable beam span.

BEAM SPAN TABLE-(beam cantilever shown in parentheses)

Species (#2 Grade)	Size	Deck Joist length Less Than or Equal To:						
		6'	8'	10'	12'	14'	16'	18'
		ft-in	ft-in	ft-in	ft-in	ft-in	ft-in	ft-in
Southern Pine	(2) 2x6	6-11 (1-8)	5-11 (1-5)	5-4 (1-4)	4-10 (1-2)	4-6 (1-1)	4-3 (1-0)	4-0 (1-0)
	(2) 2x8	8-9 (2-2)	7-7 (1-10)	6-9 (1-8)	6-2 (1-6)	5-9 (1-5)	5-4 (1-4)	5-0 (1-3)
	(2) 2x10	10-4 (2-7)	9-0 (2-3)	8-0 (2-0)	7-4 (1-10)	6-9 (1-8)	6-4 (1-7)	6-0 (1-6)
	(2) 2x12	12-2 (3-0)	10-7 (2-7)	9-5 (2-4)	8-7 (2-1)	8-0 (2-0)	7-6 (1-10)	7-0 (1-9)
	(3) 2x6	8-2 (2-0)	7-5 (1-10)	6-8 (1-8)	6-1 (1-6)	5-8 (1-5)	5-3 (1-3)	5-0 (1-3)
	(3) 2x8	10-10 (2-8)	9-6 (2-4)	8-6 (2-1)	7-9 (1-11)	7-2 (1-9)	6-8 (1-8)	6-4 (1-7)
	(3) 2x10	13-0 (3-3)	11-3 (2-9)	10-0 (2-6)	9-2 (2-3)	8-6 (2-1)	7-11 (1-11)	7-6 (1-10)
Doug fir-larch Hem-fir Spruce-pine-fir Redwood Western cedar Ponderosa pine Red pine	(2) 2x6	5-5 (1-4)	4-8 (1-2)	4-2 (1-0)	3-10 (0-11)	3-6 (0-10)	3-1 (0-9)	2-9 (0-8)
	(2) 2x8	6-10 (1-8)	5-11 (1-5)	5-4 (1-4)	4-10 (1-2)	4-6 (1-1)	4-1 (1-0)	3-8 (0-11)
	(2) 2x10	8-4 (2-0)	7-3 (1-10)	6-6 (1-7)	5-11 (1-5)	5-6 (1-4)	5-1 (1-3)	4-8 (1-2)
	(2) 2x12	9-8 (2-4)	8-5 (2-1)	7-6 (1-10)	6-10 (1-8)	6-4 (1-7)	5-11 (1-5)	5-7 (1-4)
	(3) 2x6	7-4 (1-10)	6-8 (1-8)	6-0 (1-6)	5-6 (1-4)	5-1 (1-3)	4-9 (1-2)	4-6 (1-1)
	(3) 2x8	9-8 (2-4)	8-6 (2-1)	7-7 (1-10)	6-11 (1-8)	6-5 (1-7)	6-0 (1-6)	5-8 (1-5)
	(3) 2x10	12-0 (3-0)	10-5 (2-7)	9-4 (2-4)	8-6 (2-1)	7-10 (1-11)	7-4 (1-10)	6-11 (1-8)
(3) 2x12	13-11 (3-5)	12-1 (3-0)	10-9 (2-8)	9-10 (2-5)	9-1 (2-3)	8-6 (2-1)	8-1 (2-0)	

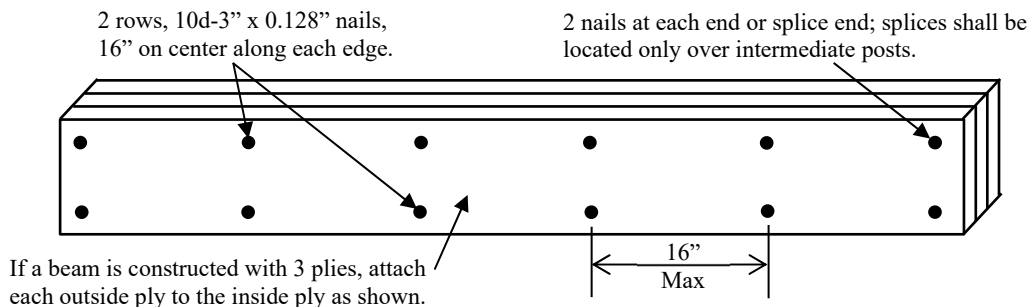

JOIST SPAN TABLE

(Design Load=40#LL+10#DL, Deflection=L/360 and wet service conditions)

	Doug Fir-Larch, Spruce-Pine -Fir(SPF), Hem-Fir #2			Southern Pine #2 (SP)			Doug Fir-Larch, Spruce-Pine -Fir(SPF), Hem-Fir #2			Southern Pine #2 (SP)		
	12" o.c.	16" o.c.	24" o.c.	12" o.c.	16" o.c.	24" o.c.	12" o.c.	16" o.c.	24" o.c.	12" o.c.	16" o.c.	24" o.c.
	Max Joist Span						Max Cantilever ^a					
	(ft.-in.)	(ft.-in.)	(ft.-in.)	(ft.-in.)	(ft.-in.)	(ft.-in.)	(ft.-in.)	(ft.-in.)	(ft.-in.)	(ft.-in.)	(ft.-in.)	(ft.-in.)
2x6	9-6	8-8	7-2	9-11	9-0	7-7	1-2	1-3	1-5	1-3	1-4	1-6
2x8	12-6	11-1	9-1	13-1	11-10	9-8	1-11	2-1	2-3	2-1	2-3	2-5
2x10	15-8	13-7	11-1	16-2	14-0	11-5	3-1	3-5	2-9	3-4	3-6	2-10
2x12	18-0	15-9	12-10	18-0	16-6	13-6	4-6	3-11	3-3	4-6	4-2	3-4

^a Maximum allowable cantilever cannot exceed L/4 or ¼ of the actual main span.

Sample Calculations for Using Joist Span and Beam Size Tables:

(Refer to tables for joist and beam size requirements)

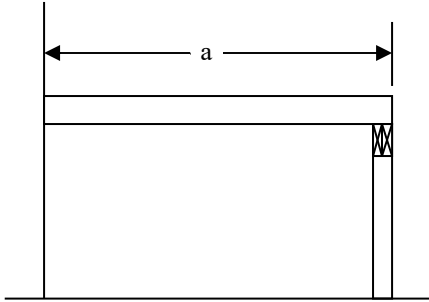
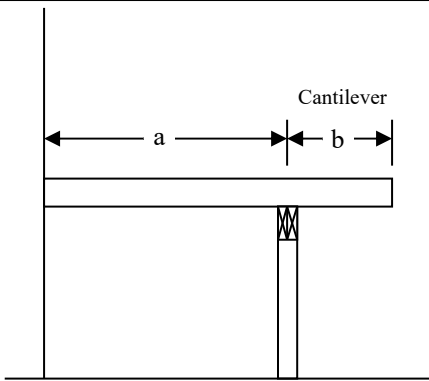
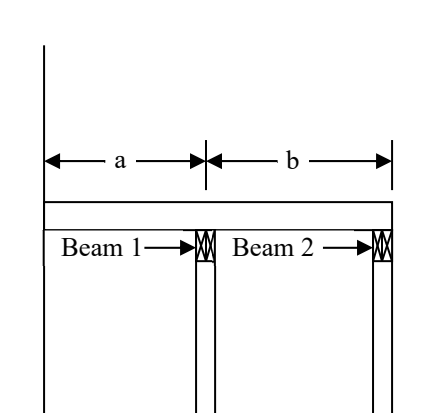
	<p><u>Example: a=12', post spacing=8', deck width 16'</u> Use the Joist Span table to find acceptable joist sizes for a 12' span: SPF #2: minimally 2x8@12" o.c., 2x10@16" o.c., or 2x12@24" o.c. SP #2: minimally 2x8@12" o.c., 2x10@16" o.c., or 2x12@24" o.c.</p> <p>Use the Beam size table with 12' joist span and post spacing 8' min: SPF #2: minimally (3)2x10 SP #2: minimally (2)2x12, (3)2x10</p> <p>Use Footing size table: Center footing (6x8=48sf trib) 19" diameter base Corner footings (6x4=24sf trib)</p>
	<p>Use (a) to determine joist size and (a)+2(b) to determine beam size.</p> <p><u>Example: a=8', b=2', post spacing=10', deck width 20'</u> Use the Joist Span table to find acceptable joist size for an 8' span/2' cantilever: SPF #2: minimally 2x8@24" o.c. for span and cantilever limits. SP #2: minimally 2x8@24" o.c. for span and cantilever limits.</p> <p>Use the Beam size table with joist length 8'+(2x2)=12' and post spacing of 10': SPF #2: no beams work, reduce span of joists or post spacing. SP #2: minimally (3)2x12</p> <p>Use Footings size table: Center footing (4+2) x10=60 sf trib, 19" diameter base Corner footings (4+2) x5=30 sf trib, 16" diameter base</p>
	<p>Use (a) or (b), whichever is greater, to determine joist size. Use (a)+(b) to determine the size of beam 1. Use (b) to determine the size of beam 2.</p> <p><u>Example: a=6', b=8', post spacing=9', deck width 18'</u> Use the Joist span table with the larger span of 8': SPF #2: minimally 2x6@16" o.c., 2x8@24" o.c. SP #2: minimally 2x6@16" o.c., 2x8@24" o.c.</p> <p>For Beam 1, use the joist length of 6'+8'=14' and a post spacing of 9': SPF #2: minimally (3)2x12 SP #2: minimally (3)2x12</p> <p>For Beam 2 use a joist length of 8' and post spacing of 9': SPF #2: minimally (3)2x10 SP #2: minimally (2)2x10, (3)2x8</p> <p>Use Footings size table: Beam 1: Center (3+4)x9=63 sf trib, 20"(interpolated) Corners (3+4)x4.5=31.5 sf trib, 16" dia base Beam 2: Center 4x9=36 sf trib, 16" dia base Corners 4x4.5=18 sf trib, 14" dia base</p>

FOOTING SIZE TABLE

(Figures assumes a 1,500 psf soil capacity and 50 psf total deck load.)

TRIBUTARY AREA	SQUARE FOOTING	ROUND FOOTING	THICKNESS
20 sf	12"x12"	14"	8"
40 sf	14"x14"	16"	8"
60 sf	17"x17"	19"	10"
80 sf	20"x20"	22"	12"
100 sf	22"x22"	25"	12"
120 sf	24"x24"	27"	12"
140 sf	26"x26"	29"	12"
160 sf	28"x28"	31"	14"

*Interpolation permitted; Extrapolation not permitted

*Minimum 12" footing for 6x6 posts

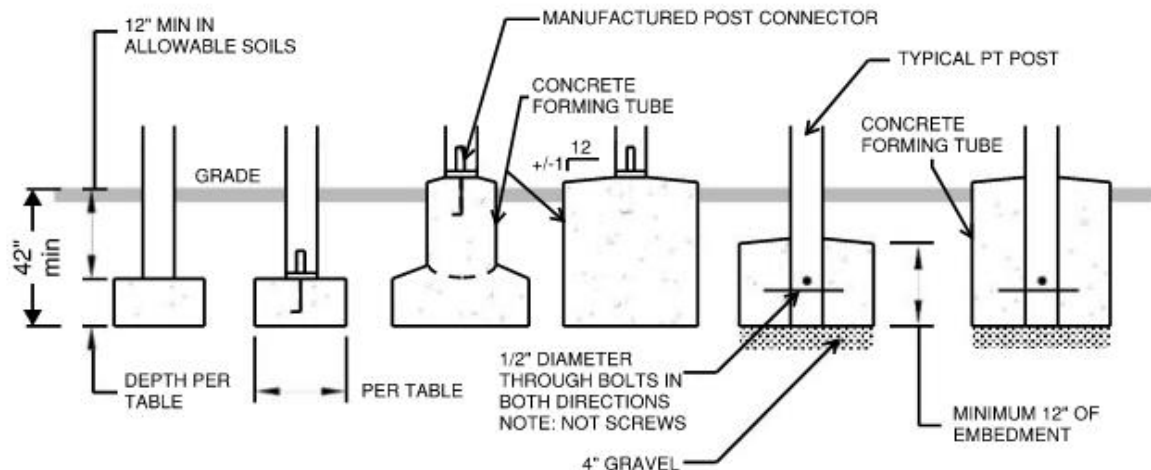
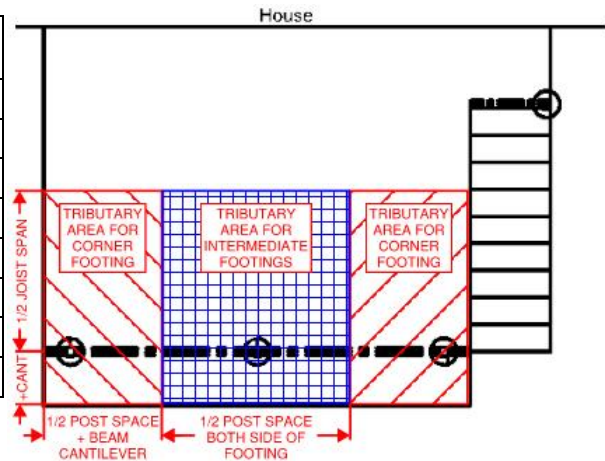

NOTE: POSTS MUST BE CENTERED ON OR IN FOOTING

Alternate Footing Types:

- Pin Piers (Ex: Diamond Piers, Handi Piers): Approved for use but must be installed per manufacturer's installation instructions. Inspection cones required to be used on pins. Caps to be sealed after final inspection so that pins can be measured at final inspection. Have limits to maximum load capacity.

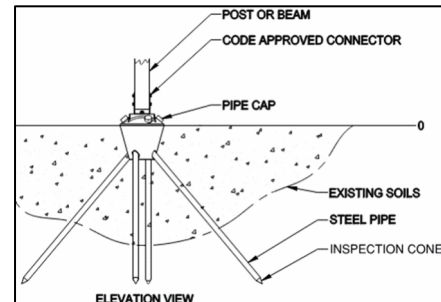

- Helical Piers: Engineered system installed by licensed installers. Must provide preliminary design for permit review **and final installation report** at final inspection. Report will show achieved torque values for each pier and corresponding bearing equivalency for each pier.

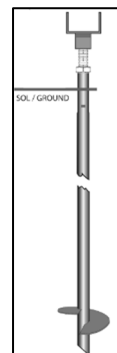

STAIR AND LANDING REQUIREMENTS

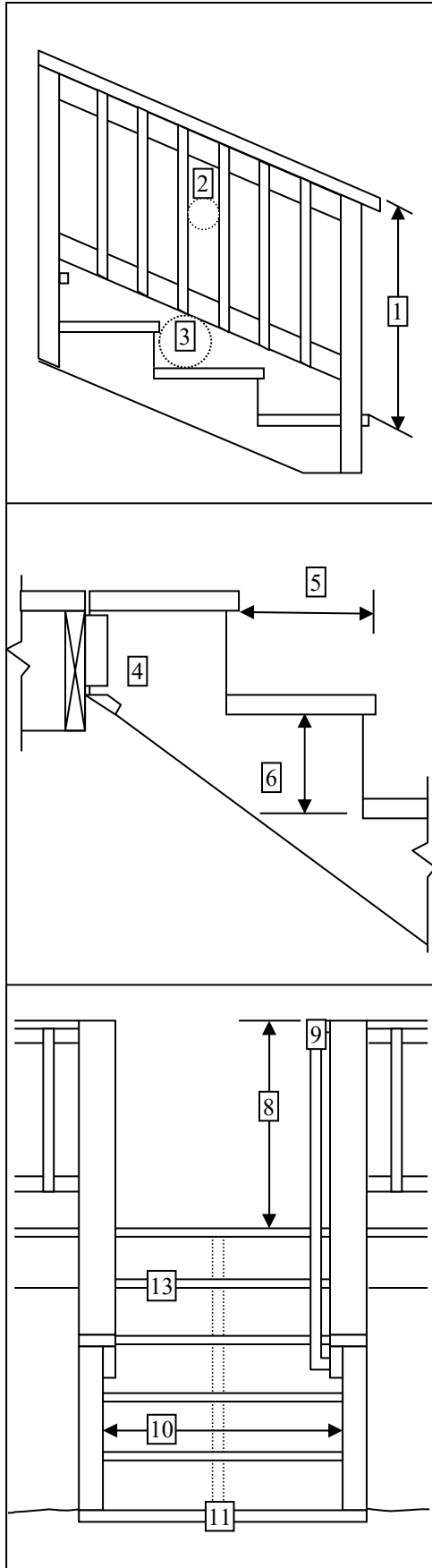

1. Stairways with a total rise of 30 inches or more above grade shall be provided with guards not less than 34 inches high measured up from the tread nose.
2. Guards shall have intermediate rails spaced so that a 4-3/8-inch sphere cannot pass through.
3. The triangular area formed by the treads and a horizontal bottom rail shall be built as to not allow the passage of a 6-inch sphere.
4. Attach stair stringers to the deck 2 x framing member with metal straps or hangers.
5. Minimum tread depth is 10 inches from nosing to nosing. All treads shall be uniform in depth within 3/8 inch from largest to smallest. A nosing of 3/4 inch to 1-1/4 inch shall be provided on stairways with solid risers, and the nosing shall also be uniform within 3/8 of an inch from largest to smallest.
6. Maximum riser height is 7-3/4 inches. Risers shall be uniform within 3/8 inch from the largest to the smallest riser.
7. When using composite lumber for stair treads, they must be installed with the specified maximum stringer spacing listed in the products testing report.
8. The grippable handrail shall be installed between 34 and 38 inches above the sloped plain formed by the tread nosing of the stairway.
9. Handrails shall be continuous the full length of the stairway and shall either terminate into a newel post or be returned into the guardrail as shown. Provide 1-1/2 inches clearance between handrail and guard.
10. The minimum width of a stairway is 36 inches. Handrails are allowed to project up to 4-1/2 inches into the minimum allowed width.
11. The bottom of stair stringers shall be supported on a hard level surface like concrete or pavers or shall be provided with treated wood blocks to keep the stringers from sinking into the ground.
12. A level landing measuring a minimum of 36" x 36" shall be provided at the top and bottom of stairways.
13. Open risers shall be constructed as to not allow the passage of a 4-inch sphere.
14. A grippable handrail is required for stairs that consist of 4 or more risers.

GRIPPABLE HANDRAILS

What the code says:

Handrail grip size. All required handrails shall be of one of the following types or provide equivalent grasp ability.

1. Type I. Handrails with a circular cross section shall have an outside diameter of at least $1\frac{1}{4}$ inches and not greater than 2 inches. If the handrail is not circular it shall have a perimeter dimension of at least 4 inches and not greater than $6\frac{1}{4}$ inches with a maximum cross section of dimension of $2\frac{1}{4}$ inches.
2. Type II. Handrails with a perimeter greater than $6\frac{1}{4}$ inches shall provide a graspable finger recess area on both sides of the profile. The finger recess shall begin within a distance of $\frac{3}{4}$ inch measured vertically from the tallest portion of the profile and achieve a depth of at least $\frac{5}{16}$ inch within $\frac{7}{8}$ inch below the widest portion of the profile. This required depth shall continue for at least $\frac{3}{8}$ inch to a level that is not less than $\frac{1}{4}$ inches below the tallest portion of the profile. The minimum width of the handrail above the recess shall be $1\frac{1}{4}$ inches to a maximum of $2\frac{3}{4}$ inches. Edges shall have a minimum radius of 0.01 inch.

What this means:

Type I:

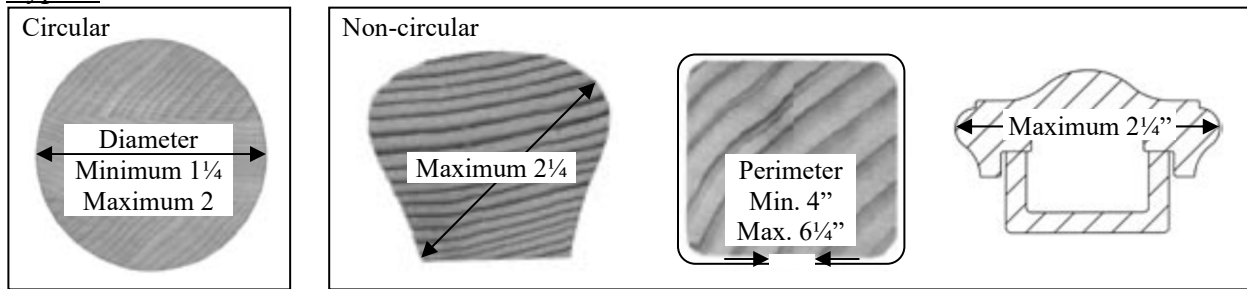

Type II:

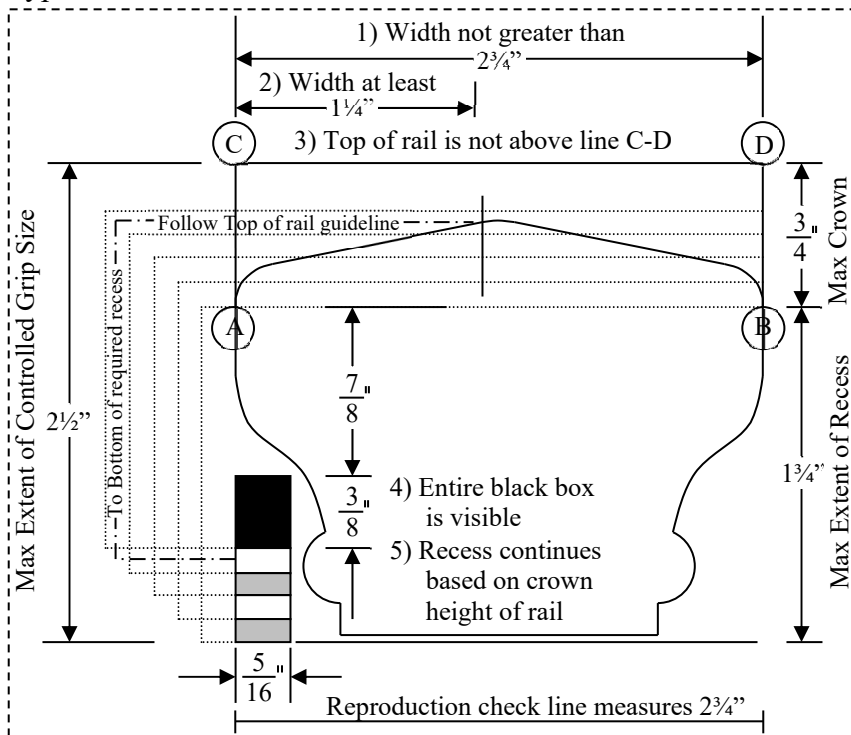

Instructions:

Position rail section with the widest point of grip at line AB and left edge touching line AC, keeping horizontal axis of rail parallel to line AB.

With rail in position, it must pass 1) thru 5) to meet the code requirements. If profile is asymmetrical both sides must pass.